

Development of a Performance Validation Tool for NSSS Control System

Suk-whun Sohn, In-ho Song, See-chaе Jeong, Jong-joo Sohn, Eun-ki Kim

Korea Power Engineering Company (KOPEC),
Daejeon, Korea
E-mail address of main author: swson@kopec.co.kr

Abstract. When a control system is supplied to nuclear power plant (NPP) under construction, static tests and dynamic tests are typically performed for evaluating its performance. The dynamic test is not realistic for validating the performance of the replaced hardware in operating NPPs because of potential risks and economic burden. We have, therefore, developed a performance validation tool which can evaluate the dynamic performances of the control system without undertaking real plant tests. The window-based nuclear plant performance analyzer (Win-NPA) is used as a virtual NPP in the developed tool and provides appropriate control loads to the target control system via hardwired cables in a manner that the interfaces are identical to the field wiring. The outputs from the control system are used as the simulation inputs of the plant model within the Win-NPA. With this closed-loop configuration, major transient events were simulated to check the performance of the implemented control system by comparing it with that of the control system model of the Win-NPA and that of the old hardware. The developed tool and the methodology were successfully applied to the hardware replacement project for Yonggwang (YGN) 3&4 feedwater control system (FWCS) in 2008. Several errors in the implemented control system were fixed through the performance validation tests and the operability tests. As a result, the control system of the YGN 3&4 has demonstrated an excellent control performance since then. On the basis of YGN 3&4 project experiences, we are performing a similar project in Ulchin (UCN) 3&4. This methodology can also be applied to other NPPs under construction as a tool for pre-operational dynamic tests. These performance tests before performing power ascension tests (PATs) are conducive to preventing unnecessary plant transients or unwanted reactor trips caused by hidden errors of control systems during PATs.

1. INTRODUCTION

Control systems play a vital role in operating NPPs within their designed purpose. Thanks to these control systems and their components, the NPPs can be operated safely and efficiently during the steady state condition and even in the event of transient condition. If a fault or an error existed in these control systems, the nuclear power plant might undergo unexpected conditions. Therefore, the performance of these control systems as well as control components should be completely verified and validated when a control system is replaced during operation or supplied to the NPPs under construction. Two kinds of tests have been typically carried out to evaluate their performance for the NPPs under construction. One is a kind of static tests such as unit tests and factory acceptance test (FAT). These tests have been performed after completing the fabrication of hardware and related software design to screen out errors that might occur in hardware manufacturing or software coding. This test can check and analyze the only static response. The other is dynamic tests including the pre-operational tests and PATs. These tests have been done to filter out the errors that could occur as a result of the combination of a dormant error and the onset of the specific set of conditions that triggers the error [1]. Even though significant amount of the root causes for the unwanted plant trips have been originated in the deficient dynamic tests of the control systems, it is not realistic to perform the real plant testing like the PAT for validating the performance of the replaced hardware in operating NPPs because of potential risks and economic losses mainly caused by the reduction of electricity production. When a re-verification is required resulting from hardware change, control algorithms change, setpoints and parameters adjustment, and so on, different verification and validation (V&V) methods need to be sought out. To solve this problem, we have developed a performance validation tool which can analyze the dynamic performances of the control systems. The developed tool and methodology can also be applied to NPPs under construction as well as operating NPPs. If pre-operational dynamic tests are performed in the NPPs under construction, it will preclude reactor from

causing unnecessary plant transients or unwanted reactor trips caused by hidden errors in the control systems during real plant testing like PATs. In China, they also tried a similar approach to evaluating their control systems in the NPP under construction recently [2].

2. DEVELOPMENT OF THE PERFORMANCE VALIDATION TOOL

The performance validation tool has been developed with the window-based nuclear plant performance analyzer. The Win-NPA is a kind of engineering simulator which is capable of simulating the transients of the NPPs with high accuracy.

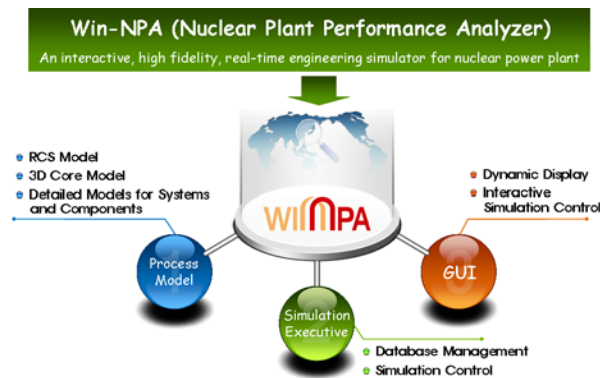

Fig. 1. Component of the Win-NPA

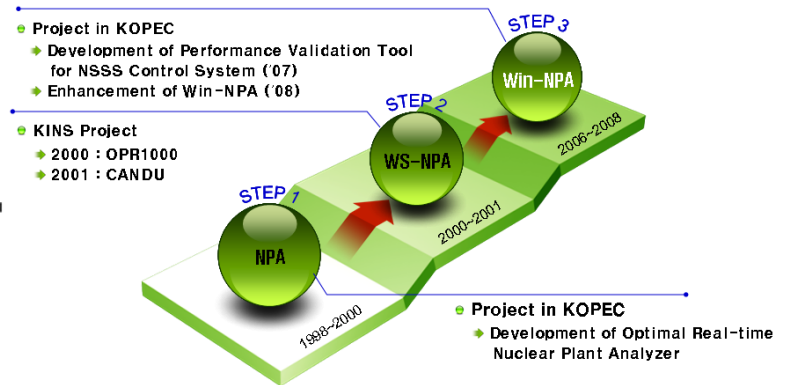

Fig. 2. History of the Win-NPA

2.1. Win-NPA

The Win-NPA is used as a virtual NPP in the developed tool. The Win-NPA combines the process model for simulating plant behaviors with graphical user interface (GUI) and simulation executive to enhance user interface as shown in Figure 1. Its simulation capability covers a wide range of nuclear power plant operations including normal, abnormal, and accident conditions. We have developed NPA since 1998 as shown in Figure 2. In step 3 of development, it has been developed as portable one unlike other full scope simulators or analyzers that were commonly used for safety analysis or training purpose.

The control system validation package and safety parameter monitoring validation package have been developed, and core operation simulation package and training package are under development for its applications.

Several computer codes are used for the design of nuclear power plants through simulation. Among them, the KISPAC [3] and the CENTS [4, 5] codes are mostly used for the performance analyses in Korea at present. The KISPAC computer code has been used for the performance analyses for the optimized power plant 1000 MW (OPR1000), while the CENTS code has been usually used for that of Westinghouse type NPPs. The CENTS code has more flexibility with respect to the simulation of various types of NPPs, and is expected to be used more widely. This code is also embedded in the workstation-based nuclear plant analyzer (NPA) which was developed between 1998 and 2001 for OPR1000. For these reasons, the CENTS code was selected as the base computer code of the Win-NPA.

2.2. Structure of the Control System Performance Validation Tool

The concept of the performance validation tool for the NSSS control system is simple. For the newly implemented control system, the Win-NPA has a connection with the actual NSSS control system hardware via signal interface module that sends the input signals from the Win-NPA to the control system and receives output signals from the control system. Figure 3 shows the structure of the

performance validation tool package. The input signals for targeted control system was generated in the Win-NPA (①). These signals were sent to the signal interface module to convert the digital signal to the analog signal (②). The converted signals were connected directly to the terminal block of the target control system hardware in a manner that the interfaces are identical to the field wiring from the viewpoint of control system (③). The output signals were returned to the signal interface module via the terminal block to convert the analog signal to the digital signal. Then, these output signals were used to the simulation inputs of the plant model within the Win-NPA. With this closed-loop configuration, it is possible to collect the data which can quantitatively analyze the performances of the control system.

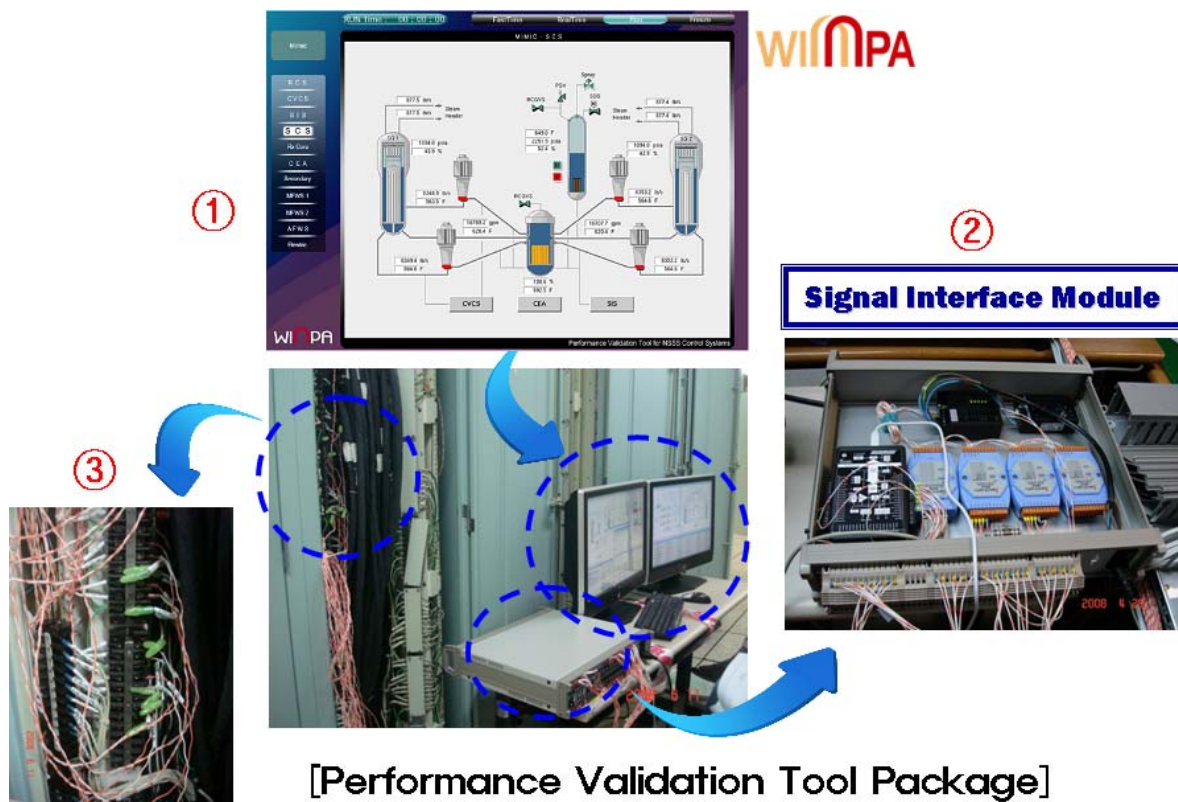

Fig. 3. Connection between Performance Validation Tool and Control System Hardware

3. APPLICATION TO OPERATING NPPS

There are twenty operating NPPs in Korea. Some operating NPPs suffer from aging of their control system and shortage of related components owing to an out-of-production of the hardware. To make matters worse, even though only one circuit of their control cards failed, the plant could experience an unplanned transient or a reactor trip because their hardware was not designed redundantly. Therefore, they want to change their old fashioned and troublesome hardware with state-of-the-art hardware that is characterized as fault-free, reliable, redundant, and proven design features. But, there is one huge obstacle to replacing the old hardware. The obstacle is that the performance and operability of the new hardware have not been proved enough. On contrary, those of the old hardware had already confirmed through PATs during startup and transient that occurred during commercial operations. Therefore, the utility has searched for the methodology that proves the operability and performance of the replaced hardware objectively. The performance validation tool had been developed under these circumstances and had been successfully applied to the hardware replacement project for YGN 3&4 FWCS in 2008.

3.1. YGN 3&4 FWCS Replacement

The following seven (7) events were chosen for simulation. These events were carefully selected out of PAT events.

- Load Rejection to House Load,
- Loss of Main Feedwater Pump,
- Reactor Trip,
- Turbine Power 10% Step Decrease (100 to 90%),
- Turbine Power 5%/min Ramp Decrease (100 to 30%),
- Valve Transfer (Increasing Direction),
- Valve Transfer (Decreasing Direction).

These major events were identically simulated in two different situations: With and without connection to the target control system hardware to check that the responses of the implemented control system are the same as that of the control system model of the Win-NPA. The control algorithm in the Win-NPA was blocked and replaced by the real hardware in performing the simulation with hardware connection. Two results from with and without hardware connections are compared with each other to find out the difference. Without significant differences, the performance of control system hardware was objectively validated and effective. This test is called performance validation test. The operability test is also done to ensure that the performance of replaced hardware is the same as the old hardware. The operability test can be applied when there is no algorithm change between new and old hardware (Figure 4).

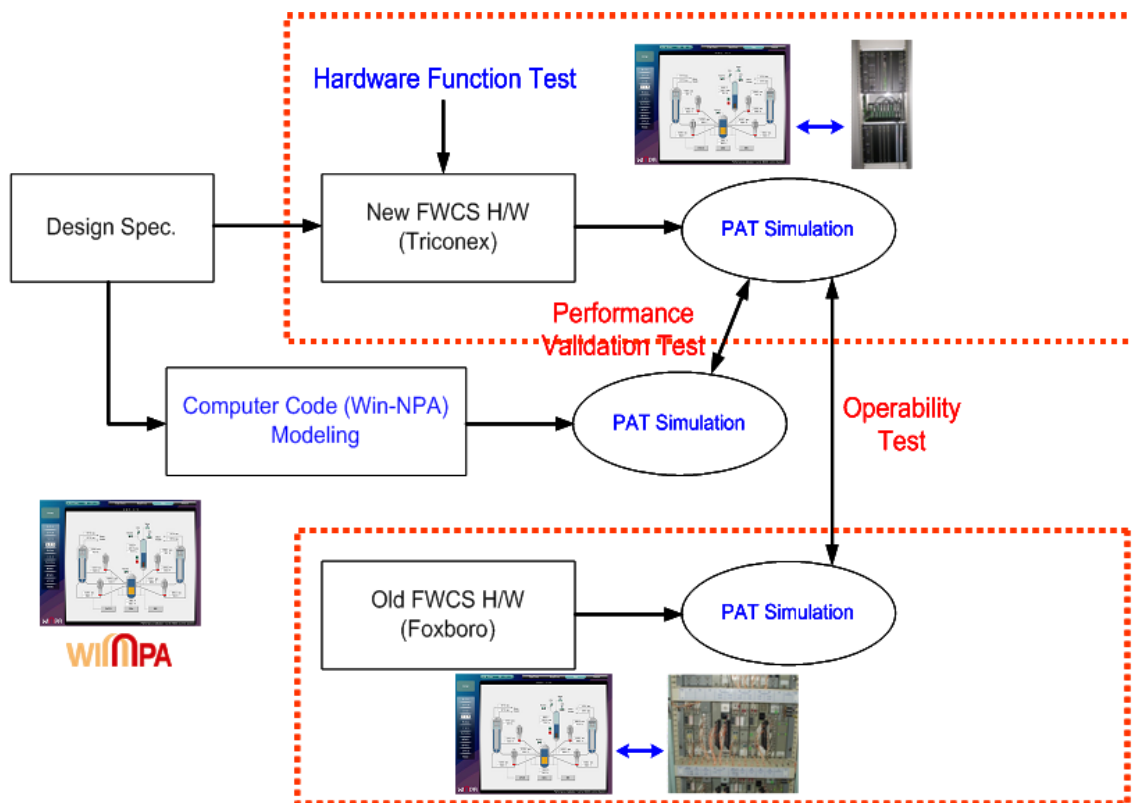

Fig. 4. Method of Performance Validation

3.1.1. Test Results

Pre-selected transient events mentioned in the previous section were simulated with the Win-NPA after thoroughly modeling the FWCS according to the design specification. This FWCS model was bypassed in the Win-NPA, and the input and output signals of control system were connected with the real FWCS hardware. The same transients should be simulated. These two results were compared in

graphs to prove whether the new FWCS hardware was properly manufactured in accordance with the design specifications.

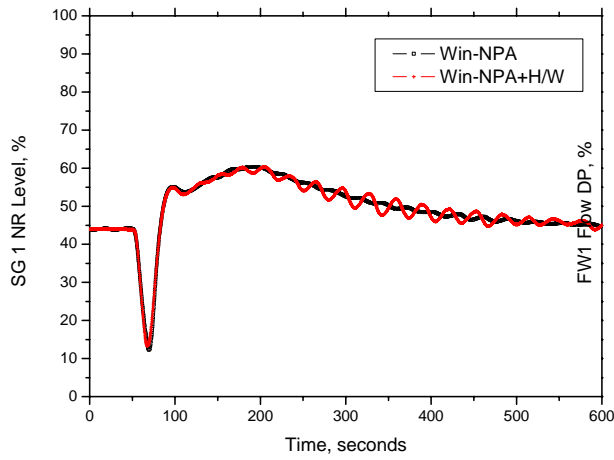

Fig. 5. SG level at Load Rejection at Load Rejection (Performance Validation Test)

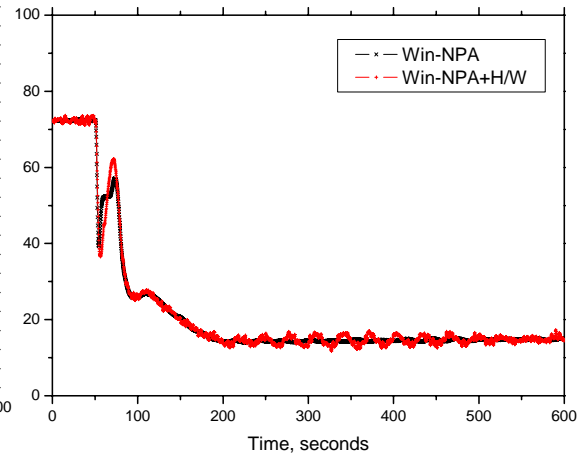

Fig. 6. FW flowrate at Load Rejection at Load Rejection (Performance Validation Test)

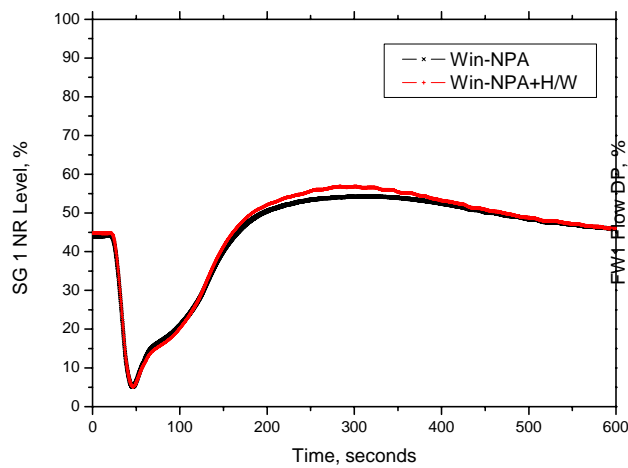

Fig. 7. SG level at LOMFP (Performance Validation Test)

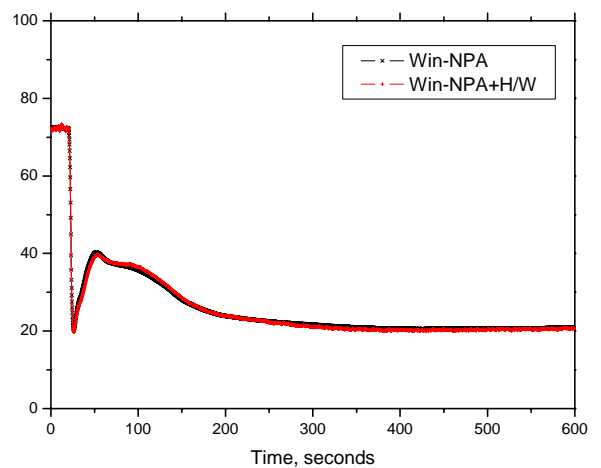

Fig. 8. FW flowrate at LOMFP (Performance Validation Test)

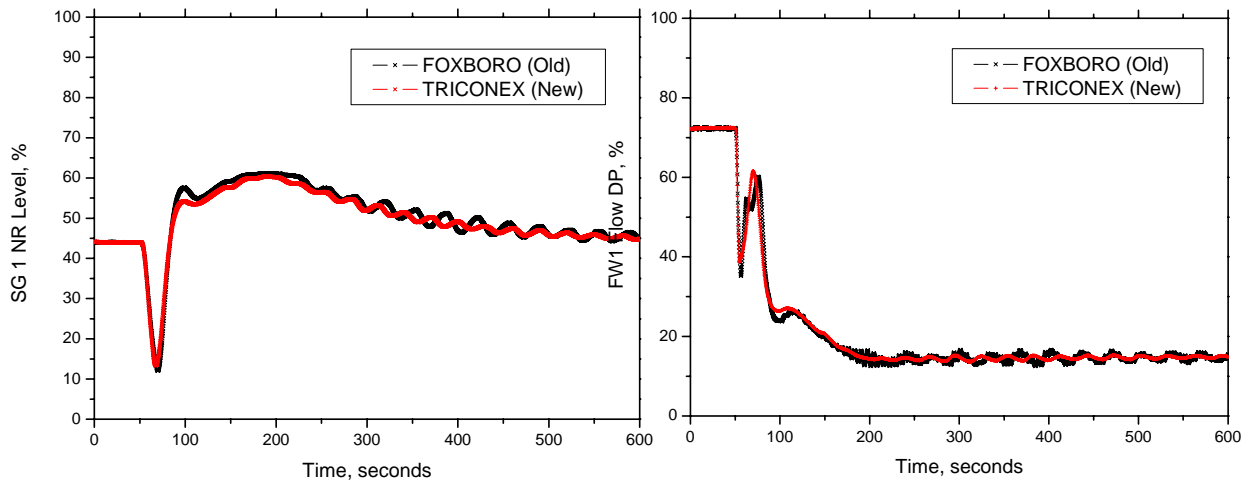

Fig. 9. SG level at Load Rejection (Operability Test)

Fig. 10. FW flowrate at Load Rejection (Operability Test)

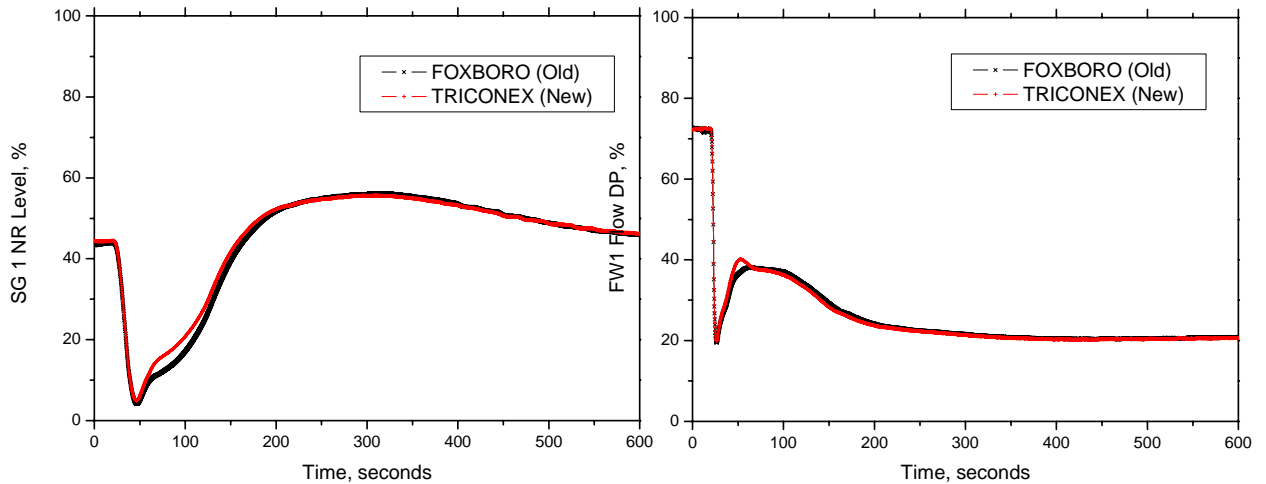

Fig. 11. SG level at LOMFP (Operability Test)

Fig. 12. FW flowrate at LOMFP (Operability Test)

Figures 5 and 6 are the steam-generator (SG) level and feedwater (FW) flowrate responses of the load rejection event, respectively. Figures 7 and 8 are those of a loss of a main feedwater pump event. These trends between two simulations are very similar each other. Differences mainly came from signal noise and delay in signal interface. Noise filtering algorithm was added to minimize the differences caused by noise. In addition to pre-selected tests, some special tests like CPU fail test, communication fail test, and several functional tests were performed.

The performance of the new hardware was also evaluated by comparing it with that of the old hardware. The performance and operability of the old hardware were already confirmed through commercial operation and the PAT during the startup period. The operability test is done to ensure that the operability of replaced hardware is the same as that of old hardware. This test method can be applied when there is no algorithm change between new and old hardware. Figures 9 and 10 are the steam-generator (SG) level and feedwater (FW) flowrate responses of the load rejection event, respectively. Figure 11 and figure 12 are those of a loss of a main feedwater pump event. Thus the operability of new hardware was proven to be robust according to these data.

During the project, we conducted functional test twice, performance validation test four times, operability test twice as well, which considerable errors were found through these tests. After correcting all these errors, The YGN 3&4 successfully reached a full power level without any disturbances. The new feedwater control system also showed good response when the plant suffered a loss of main feedwater pump event.

3.2 UCN 3&4 FWCS Replacement

After the YGN 3&4 successfully replaced the old FWCS hardware, a decision was made to change the old hardware of UCN 3&4 since the hardware is the same with YGN 3&4. Accordingly, the similar project is on going now for the UCN 3&4.

4. FUTURE PLAN

On the basis of successful experience of YGN 3&4, the performance validation test will be extended to NPPs under construction like Shin-Kori 1&2. If pre-operational dynamic tests are performed, errors in the control systems can be checked and corrected before the PATs. Furthermore, the performance of control valves also can be tested and evaluated with the configuration shown in Figure 13. It is widely known that about 30% of control problems are caused by valve problems such as a stiction of a positioner, low or large air flow, and improper size. As the performance of integrity of control systems and control valves is verified before the PAT, unnecessary transients or a reactor trip with control problems will be avoided during the PAT.

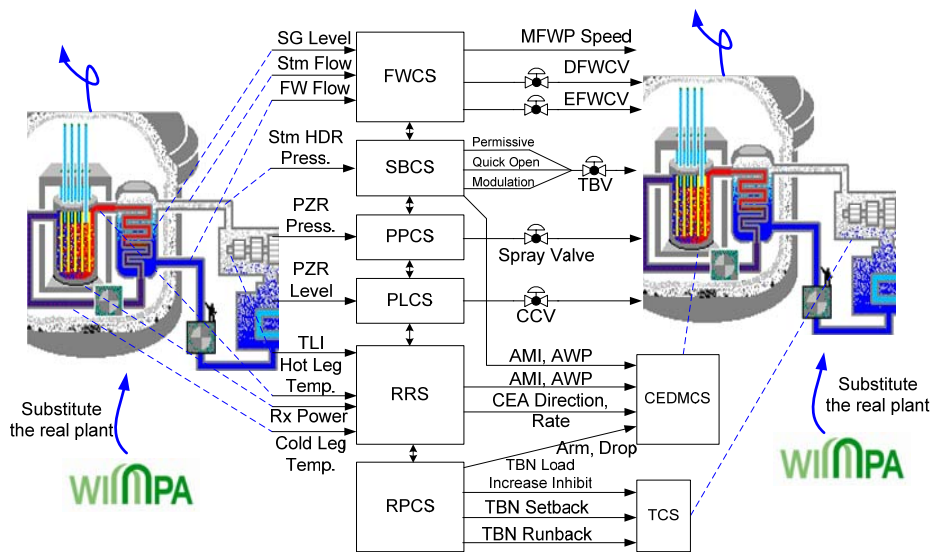

Fig. 13. Interfacial Configuration between Performance Validation Tool and Control Systems and Control Valves

5. CONCLUSIONS

The new tool and methodology have been developed to validate the performance of the NSSS control systems which need to be replaced. They were applied to operating NPPs such as YGN 3&4 and UCN 3&4. Several errors which were found in the replaced FWCS hardware have been properly corrected before commercial operations. Should there be no artificial dynamic tests, the plant would be suffered from unwanted transients or a reactor trip during a startup. Such remedial measures are conducive to precluding probable errors which might occur during the extended refueling period. These measures have been applied to the NPPs under construction as a tool for pre-operational dynamic tests. This tool has been upgraded for better user interface and the applications, and our efforts for upgrading the system reliability will be continued in the future.

REFERENCES

- [1] K. Korsah, et al., “Industrial Survey of Digital I&C Failure”, ORNL/TM-2006/626, December 2006.
- [2] Meng Lin, et al., “Applying Engineering Simulator to Verification and Validation of Digital I&C Nuclear Power Plant”, ICONE17-75234 (Proc. 17th Int. Conf. on Nucl. Eng.), Brussels, 2009.
- [3] “Technical Manual for the KISPAC,” KOPEC, August 1999.
- [4] “User’s Manual for the CENTS Code,” Westinghouse Electric Company, March 2004.
- [5] “Modeler’s Manual for the CENTS Generic Control Systems,” Westinghouse Electric Company, February 2004.
- [6] U. S. Kim, et al., “Development of Performance Verification Tool for Nuclear Steam Supply System Control Systems”, 16th PBNC, 2008.